

Tachometer CT 50

KEY POINTS

- Easy to use
- HOLD function
- Built-in probe
- Auto shut-off : 20 minutes

FEATURES OF THE HOUSING

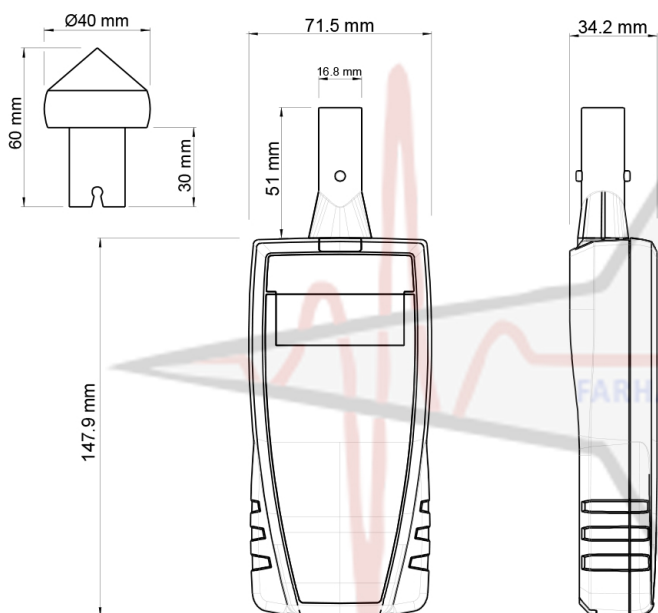

Material : ABS

Protection : IP54

Display : 1 line
LCD 1 x 5 digits
Size : 50 x 20 mm

Height of digits :

Values : 9.2 mm

Units : 4.7 mm

Weight : 200 g (with batteries)



TECHNICAL FEATURES

Parameter	Optical velocity	Contact velocity
Measuring units	rpm	rpm, m/min, ft/min, in/min, m/s
Measuring Range	From 0 to 60 000 rpm	From 0 to 20 000 rpm
Accuracy*	From 60 to 10 000 rpm : $\pm 0,3\%$ of reading ± 1 rpm From 10 001 to 60 000 : ± 30 rpm	From 30 to 20 000 rpm : $\pm 1\%$ of reading ± 1 rpm
Resolution	1 rpm	1 rpm
Measuring elements	Phototransistor, sighting distance max. 40cm	ETC Adapter positioned on optical probe
Operating temperature	From 0 to +50 °C	
Storage temperature	From -20 to +80 °C	
Power supply	4 batteries AAA LR03 1.5 V	
Battery life	20 hours	
Conformity	Directives CEM 2004/108/CE and NF EN 61010-1	

*All the accuracies indicated in this technical datasheet were stated in laboratory conditions, and can be guaranteed for measurements carried out in the same conditions, or carried out with calibration compensation

SUPPLIED WITH

Instruments are supplied with an adjustment certificate, a reflective tape, a contact tip and a soft case.



ACCESSORIES

- Adjustment certificate
- Transport case
- Magnetic protective housing



MAINTENANCE

We carry out calibration, adjustment and maintenance of your instruments to guarantee a constant level of quality of your measurements. As part of Quality Assurance Standards, we recommend you to carry out a yearly checking.

GUARANTEE

Instruments have 1-year guarantee for any manufacturing defect (return to our After-Sales Service required for appraisal).

USE OF THE INSTRUMENT

Take a measurement

- Switch on the instrument by pressing briefly on « **On/Off/Hold** ».
The instrument displays its name « CT50 » then the measurement.

Hold the measurement

During measurement :

- Press briefly on « **On/Off/Hold** » to hold measurement.
« *Hold* » appears on the screen and the measurement is fixed.
- Press again briefly on « **On/Off/Hold** » to exit the Hold function.

Select measurement

During measurement :

- Press briefly on « **Select** » to select the desired unit of measurement.

Select the type of velocity (contact or optical)

The instrument is on.

- Pressing longer on « **Select** ».
« **Cont** » or « **Optic** » flash.
- Press briefly on « **Select** » to select contact velocity « **Cont** » or optical velocity « **Optic** ».
- Pressing longer on « **Select** » to confirm the type of velocity.

How to change batteries

- Remove the front part at the back of the instrument.
- Replace used batteries by new batteries AAA LR03 1.5 V.
- Replace the front.

« Select » key

« On/Off/Hold » key



Auto shut-off : the instrument switches off if not used during 20 minutes.



Once returned to KIMO, required waste collection will be assured in the respect of the environment in accordance to 2002/96/CE guidelines relating to WEEE.

+982165565901

+982144584619

+989034119385

پتروفرهان گستر جنوب

FGJ-NDT.IR

DIGINDT.IR