



LED Portable Industrial Film Viewer

User's Manual

LCNDT[®]

پتروفرفهان گستر جنوب

DIGINDT.IR

FGJ-NDT.IR

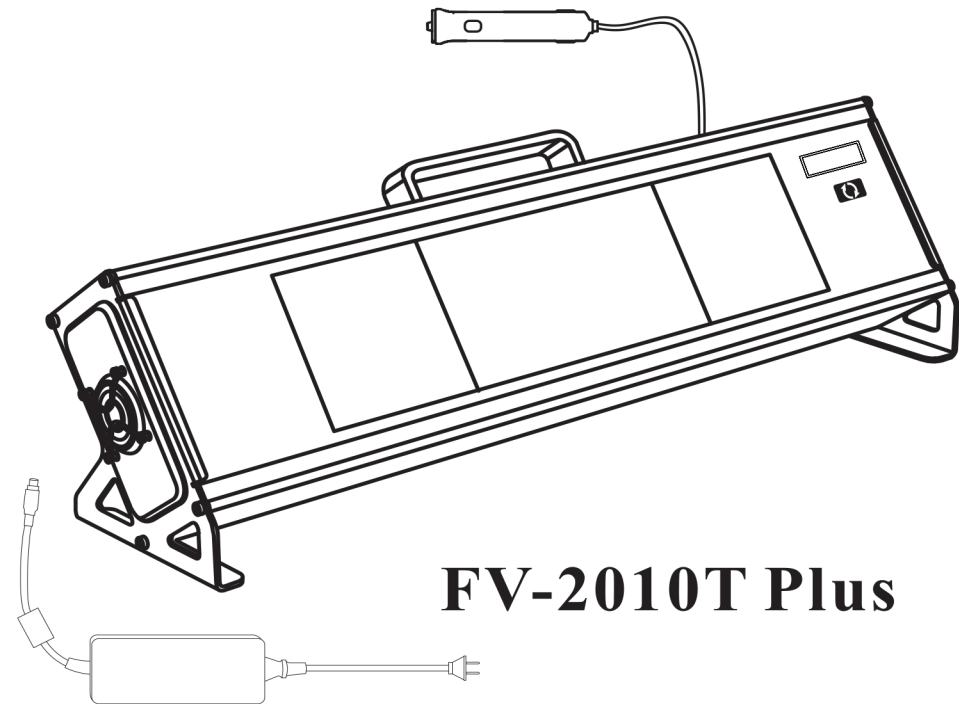

FV-2010T Plus

LCNDT[®] Wen Zhou Lu Cheng NDT Equipment Corp.

Address: RM.308,Kang Yuan South Building XinCheng Avenue,
Wenzhou City, Zhejiang Province, P.R.China.

Post Code: 325000

Tel: 86-577-88293040, 88293242, 88293909

Fax: 86-577-88259689

Http://www.Lcndt.net

E-mail: Lcndt@163.com

Wen Zhou Lu Cheng NDT Equipment Corp.

Instruction:

FV-2010T Plus intelligent LED Industry X-ray Film Viewer is a kind of innovative viewer that developed by our company joint with the American company. It not only can inspect films, but also can measure the film density accurately.

Totally different from the traditional concept of both viewer and densitometer, since now you can complete all assessment tasks with only one unit of FV-2010T Plus.

FV-2010T Plus origin from the V Volume of U.S. ASME standards, which is equipped with original U.S. probe, and has excellent optical properties and stability, and the tolerance is less than +/- 0.02 D. The powerful auto-calibration function of this unit (patent technology), can make it adapt to the films from various of brands and film bases.

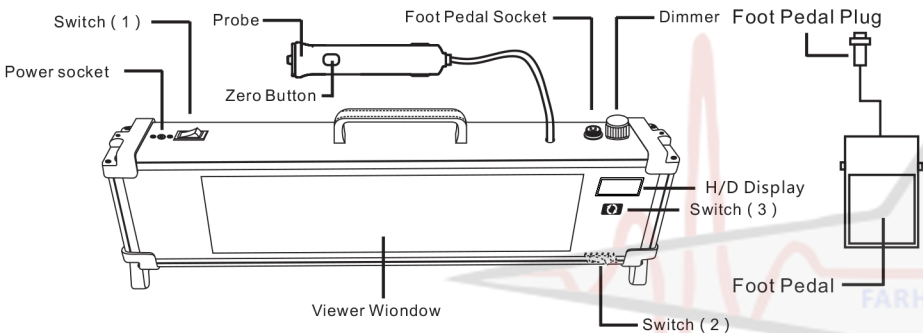

The size of light will be switched as below:



Features:

1. The real cold light source, super bright LED: built-in special large Angle super power LEDs, maximum power with 150W.
2. The built-in original American optical probe, measuring the density of films within 5.0 D.
3. Long life light source: work time will be more than 50000 hours, which is ten times than common fluorescent lamp. With our temperature protection system, can even improve the life of the light source.
* The life of the light source: the brightness of light attenuation by 30% at most when using.
4. Adjustable brightness, MCU controlled PWM pulse width modulation method is adopted to realize stepless light adjustment, with ultra wide dimming range 5% - 100%, to be adjusted according to your requirement.
5. Start fast: because of the characteristic of the LED quick start, the start time of light source less than 5 ms, different with fluorescent lamp, it's unnecessary to preheat time, and start times will not affect the life of light source.

Specifications:

1. The brightness: See the test report
2. Observable film density: See the test report
3. The average color temperature: 7000k
4. The uniformity of viewing surface: See the test report
5. Scattering coefficient: See the test report
6. Max. Viewing Area: 400x100 mm
7. Max. Measuring density: 5.0D
8. Measurement tolerance: +/- 0.02 D
9. Measurement repeatability of density: +/- 0.01 D
10. Diameter of aperture: 3mm
11. Power supply: 47-63 Hz 85 ~ 264 VAC (Full voltage range),
12. Power consumption: 150W
13. Dimension: 23.6 3.1 6.3", 600 80 160mm (length x width x height)
14. Weight: 4 Kg

Viewer:

Pedal mode (recommended) : Press switch (2) to ON, start the foot switch function. Plug in, press the main power switch (1), make the power on. At this time, you will see the viewer with the lowest brightness light, you can check the film series number conveniently, can also act as the role of reading lamp. Low brightness can avoid light hitting the eyes directly, alleviate the damage of staffs suffer from strong light glare. Step on the foot switch, viewer lighting normally, then you can stepless adjust the light through the dimmer knob in order to achieve to your requirement.

Manual mode: Press switch (2) to OFF, close the foot switch function. Plug in, press the main power switch (1), make the power on. then you can stepless adjust the light through the dimmer knob in order to achieve to your requirement.

Densitometer:

When measuring density, to obtain the stability of initial intensity light, we recommend that you use the manual mode of viewer. Adjust the dimmer knob, adjust to appropriate brightness (if measuring density above 5.0 D, we recommend using maximum brightness). Put the probe of detect pen aim at the center area of viewing screen, and fully touch panel, avoid light-leaking, hold the zero button, loosen the zero button until the digital screen display 0.00. Then, put the film on the viewing panel, aim at the measure points of film where you want with the probe of detect pen, and fully touch the film, the values of density will be display at the digital screen automatically.

Trouble Shooting:

- Case 1:** No matter how to adjust the dimmer, the luminance is low and fixed.
Solution1: Please check the switch (2) is pressed in "ON" or "OFF". If it is pressed in "ON", that means you chose to use foot mode, so whenever you press down the foot-switch, the viewer will start-up in the luminance that you have already set, you can adjust the luminance by dimmer.
- Case 2:** Plugged in, and turn on the switch (1), but the viewer is dark.
Solution1: Firstly check the switch (2) is pressed in "ON" or "OFF". If it is pressed in "ON", that means you chose to use foot mode. Secondly check that you have plugged the foot-pedal in to viewer or not. If you plug the foot-switch into the viewer, this kind of case still remain, please contact us with out delay.
Solution2: Firstly check the switch (2) is pressed in "ON" or "OFF". Secondly turn the switch (2) to "OFF", that means you chose to use hand mode. If you do this operation, this kind of case still remain, please contact us with out delay.

+982165565901

+982144584619

+989034119385

Tehran, Tehransar