

Fluke-700LTP-1 Low-Pressure Test Pump

Introduction

The Fluke-700LTP-1 Low-Pressure Test Pump is a portable, dual source of vacuum and pressure. Each pump incorporates a vacuum and pressure selector and fine adjustment control. The pump has the following specifications:

- Output pressure: 0 to 100 psi / 0 to 6.9 bar
- Output vacuum: 0 to -13 psi / 0 to -900 mbar
- Exposed Materials: Aluminum, silicon, neoprene, stainless steel, Buna-N
- Adjustment: Fine volumetric pressure and vacuum adjuster
- Dimensions: 150 mm x 100 mm
- Weight: 226 grams or .5 lbs (pump only)

Box Contents

- Fluke 700LTP-1 Low-pressure Test Pump
- 1/8 in NPT male/female tee
- (2) 1 m hoses
- (4) 1/8 in NPT male quick connects
- (2) 1/8 NPT female to 1/4 in BSP female
- Seal Kit
- Instruction Sheet

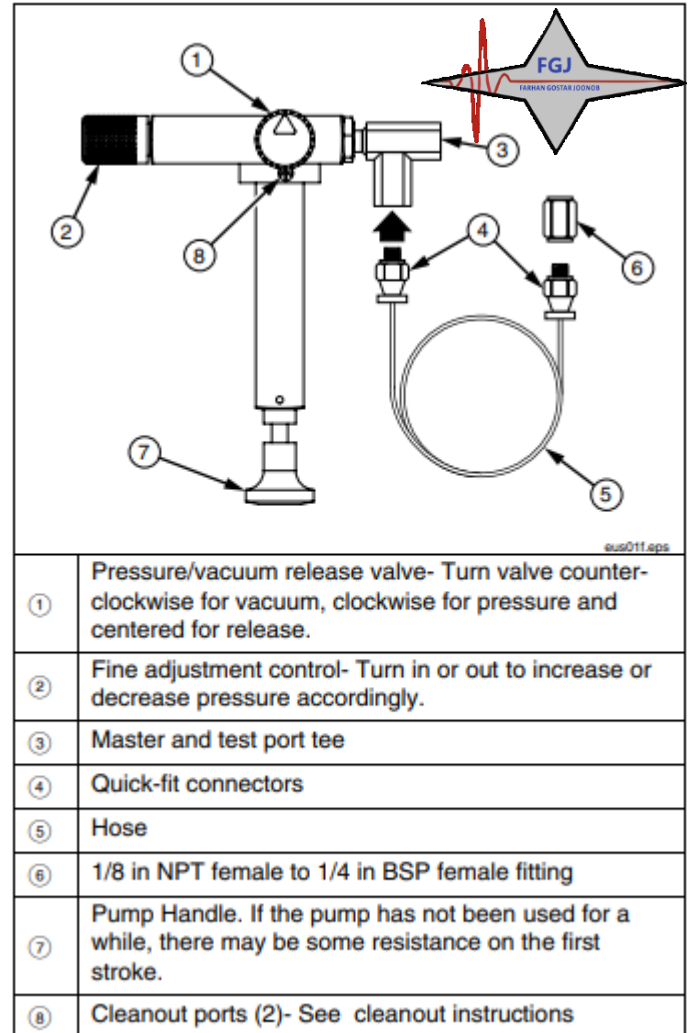

Figure 1. Features

Guidelines for Use

1. Connect a pressure calibrator or pressure module to the quick-fit connector (item ④) at the end of one of the flexible hoses (item ⑤).
2. Connect the unit under test to the quick-fit connector (item ④) at the end of the second flexible hose (item ⑤), choosing correct adapters (item ⑥) and seals.
3. Turn the fine adjustment control to mid-range.
4. Set control valve to pressure.
5. Operate handle (item ⑦) until the pressure is close to the required value.

Notes

- The pressure may settle for up to one minute after increasing pressure due to the thermodynamic effects, settling of seals and expansion of the flexible hose.
- On very high resolutions such as 1 mbar or 0.1 inches of water, small movements of the tubing may result in noticeable pressure changes.

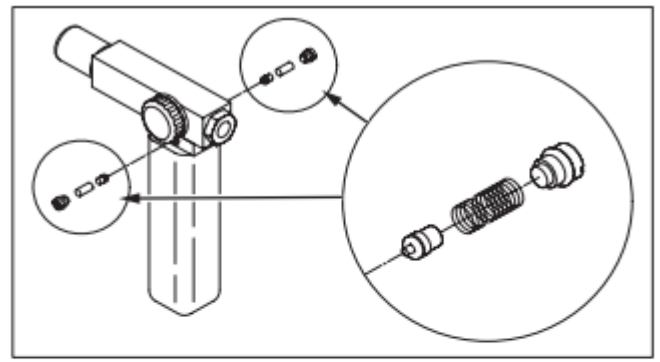

Figure 2. Disassembly

eus021.eps

6. Turn the fine adjustment control (item ②) in to increase pressure or out to decrease pressure until required pressure is reached.
7. Reduce pressure by careful use of the pressure release valve (item ①).
8. Achieve vacuum using the above procedure with the pressure / vacuum selector (item ①) in the vacuum position.

When testing for leaks, you may notice that air is drawn in or expelled from around the pressure / vacuum selector. This is normal operation.

If the pump appears to lose pressure, then the procedure above should be repeated, ensuring new seals are used, adapters are tightened sufficiently and the pressure release valve (item ①) is tightened firmly. The connections to the handheld test system are sealed with o-ring or bonded seals and should not leak.

Pump Valve Assembly Cleaning Instructions

Occasionally, the 700LTP-1 may not work properly due to contamination of the internal valve assembly. Use the following procedure to clean the valve assembly. If the procedure does not fix the problem, a rebuild kit (2812587) may be ordered.

1. Using a small screwdriver, remove the 2 valve retention caps located on opposite sides of the pump below the pressure/vacuum switch.
2. Gently remove the spring and o-ring assembly. This includes several small components. Remove with care. See Figure 2.

3. Set aside the valve assemblies and clean out the valve body using a cotton swab soaked in isopropyl alcohol.
4. Repeat the process several times using a new swab until clean.
5. Operate the pump handles several times and recheck for contamination.
6. Clean the o-ring assembly and the o-ring on the retention caps with isopropyl alcohol and inspect the o-rings closely for any damage or excessive wear. Replacements are included in the repair kit.
7. Inspect the springs for wear or loss of tension. They should be approximately 8.6 mm long in the relaxed state. If shorter, they may provide sufficient sealing tension. Replace if needed.
8. Once all parts have been cleaned and inspected, reinstall the o-ring and spring assembly into the valve body.
9. Reinstall the retention caps and gently tighten each cap.
10. Seal the output port and operate the pump to at least 50 % of capacity.
11. Release the pressure and repeat several times to ensure that the o-rings seat properly.

Replacement Parts

- Hose Assembly, Fluke PN 2815714
- Rebuild Kit, Fluke PN 2812587

پتروفهران گستر جنوب

FGJ-NDT.IR

DIGINDT.IR

+982165565901

+982144584619

+989034119385